

CHALLENGE REGULATION

PREMISES

- I. Enel S.p.A. (“**Enel**”) is the holding company of a multinational group of companies (under its direct or indirect control “**Enel Group**”), and a leading integrated player in the global power and renewables markets. At global level, it is the largest renewable player in the private sector with around 66 GW of renewable installed capacity, the foremost electricity distribution network player by number of grid customers served, with approximately 69 million end users around the world. Moreover, Enel Group is the biggest retail operator by customer base with more than 55 million customers worldwide. The Enel Group is made up of more than 60.000 people from around the world whose brilliant work is based on our values of Trust, Innovation, Proactivity, Flexibility and Respect.
- II. In line with its strategic positioning, Enel has placed environmental, social, economic and financial sustainability at the core of its corporate culture and is implementing a sustainable development system based on the shared creation of value, both within and beyond the company. This strategic vision has led Enel to become a member of the United Nations Global Compact, committing to a tangible contribution toward achieving the 17 Sustainable Development Goals (SDGs).
- III. At Enel, we believe that inspiration and innovation can come from anywhere. For this reason, we constantly look beyond our organization, seeking ideas, projects, and expertise from diverse sources. We are promoting modern collaboration platforms that enable contributions from university students, energy start-ups, and global industrial partners alike. Only by rethinking the way we innovate we can truly transform the industry, developing technologies and solutions capable of disrupting traditional markets and creating entirely new ones, ultimately improving people’s lives.
- IV. It is within this framework that we have decided to launch the present challenge (the “**Challenge**”). With this Challenge, Enel intends to rethink the aesthetics of wind power plants through innovative solutions: combining functionality, design, innovation and sustainability to enhance the harmony between infrastructure and landscape, while reducing the environmental impact. The proposed solutions must meet the criteria of increasing environmental and landscape integration, technical and functional feasibility, flexibility of use and economic sustainability. This Challenge aligns with Enel’s strategic objectives of fostering innovation, sustainability and social responsibility.

PRELIMINARY INFORMATION

PLEASE NOTE: before sending your proposed solution (the “**Solution**”), it is required that you expressly accept this regulation (“**Regulation**”) by ticking the appropriate boxes on the web page where the Challenge is presented. Upon acceptance, this Regulation, together with the [Terms of Use](#) of the Platform (as defined below) constitute a valid and binding agreement governing all aspects of your participation in the Challenge. For sake of clarity, provisions specific to any other challenge are not applicable herein. In case of conflicts between the Terms of Use and this Regulation, the provisions of this Regulation prevail.

The proponent of this Challenge is Enel S.p.A., an Italian company with registered office at Viale Regina Margherita, 137, 00198 Rome, fully paid-up share capital of Euro 10.166.679.946,

Group VAT No. 15844561009, R.E.A. 756032. Within this challenge Enel is acting in its own interest and in the interest of the other companies of Enel Group.

The Challenge, conducted through an open procedure, is structured as a two-phases competition, aimed at identifying the best proposed Solutions among those submitted by all the participants within the established deadlines, in compliance with this Regulation.

In consideration of the general purpose of the Challenge, as set forth in section IV of the Premises, the two phases will consist of:

- **PHASE 1:**
Submission of idea proposals for new types of wind turbines.

- **PHASE 2:**
Submission of a detailed design of the proposed Solution for new types of wind turbines.

From the PHASE 1 the proposed Solution must integrate engineering considerations, ensuring that the design concept achieves an optimal balance of aesthetics, functionality, and industrial feasibility.

More details concerning each phase are provided in the technical specifications (“**Technical Specification**”), attached hereto, which are integral part and parcel of this Regulation.

The PHASE 1 of the Challenge is managed by means of the Open Innovability[®] Portal (the “**Platform**”). Participants should periodically consult the Platform to check for any additional communications of relevance to the Challenge. To ensure equal participation conditions: (i) all communication regarding the competition and interactions between Enel and the participants, including requests for clarifications and the submission of the documents concerning the proposed Solutions, will exclusively occur through the Platform or the alternative means that will be communicated by Enel from time to time, and (ii) all requests for clarification received by Enel which are deemed to be of common interest may be answered by publishing the same, with the relevant answers, on a dedicated section of the Platform.

The PHASE 2 of the Challenge shall be conducted in accordance with the modalities that will be duly communicated by Enel in a timely manner. Such communication shall be made through the Platform and/or any other means deemed appropriate by Enel, including but not limited to email notifications.

The official language of the Challenge is English. Only documents and Solutions presented in English will be considered for the purpose of the Challenge.

TIMETABLE AND DEADLINES

The following table shows all the Challenge key dates and deadlines:

Event	Date and time (Italian time - CET)
Publication of the Challenge	April 2 nd , 2025

Deadline for submission of Solutions for PHASE 1	June 16 th , 2025 – 23:59
Declaration of Participants admitted to PHASE 2	July 1 st , 2025
Deadline for submission of Solutions for PHASE 2	September 29 th , 2025 – 23:59
Declaration of winner Solution/s	November 10 th , 2025

The Participants (as defined below) will have until the above terms to prepare their Solution in response to the Challenge (in compliance with the request of each phase) and to submit it on the Platform, or the other means that will be indicated by Enel, together with any necessary documentation.

Please note: when using the Platform the time the “Send your solution proposal” button on the Platform is pressed, not the time the relevant web page is opened, counts for the respect of the submission deadlines. If the button is pressed after the date/time indicated submission will not be successful.

Enel may at its own discretion extend the deadlines mentioned above and to announce such extensions by means of the Platform and/or other means that will be deemed appropriate by Enel. The implementation of such time extension will not require any modification of this Regulation.

TERMS AND CONDITIONS

1. PARTICIPATION

1.1. ELIGIBILITY

Participation to the Challenge is open to all individuals and entities that meet the eligibility requirements provided herein. Those who will accept the terms and conditions of this Regulation, proposing a Solution that complies with the Technical Specification (e.g. in terms of cost and technical conditions) is considered to be participant of this Challenge (“**Participant**”).

The participation to the Challenge is reserved exclusively to:

- Students or recent graduates from engineering, architecture or design universities;
- Professionally qualified architects or architecture firms;
- Professionally qualified designers or design firms;
- Professionally qualified engineer or engineering firms;
- Research institutions and universities;
- Commercial companies and start-ups.

Participants, by sending their application and their proposed Solution, shall also provide any useful document in order to demonstrate their eligibility to the Challenge as well as all the other documents specifically requested by Enel, including without limitation to the following documents collected in single compressed folder (ZIP), that together with the other files (e.g. constituting the Solution) does not exceed the size of 35 MB:

- Identity document of the Participant (or of its members involved in the Challenge, whether the Participant is a company, a firm or a Team, as defined below);

- CV of the Participant (or of its members involved in the Challenge, whether the Participant is a company, a firm or a Team);
- Self-declaration of compliance with the eligibility requirements, absence of exclusion grounds and express unconditioned acceptance of this Regulation, including clauses specified at the end of the same, by the Participant (or of its members involved in the Challenge, whether the Participant is a company, a firm or a Team);
- List of members forming part of the Team constituting the Participant, with the indication of the Team leader (if applicable).

Enel reserves the right to verify the Participants' eligibility by analyzing the provided documents and/or to carry out more accurate verification in order to attest the actual Participant's qualifications. Failure to provide the above documents by the deadline for submitting the documents for PHASE 1 will result in the Participant's exclusion from the Challenge.

1.1.1. Teams

Participants may consist of single individuals or entities and/or of groups formed by up to a maximum of three individuals or entities ("**Teams**"). In case of Teams, their components will be considered jointly as a single Participant for the purposes of this Regulation, being intended that all the members of each Team shall abide with the obligations provided herein. The authorship of the proposed Solution will be recognized to all members of the Team.

In case of a Participant constituted by a Team, a Team leader must be appointed by the other Team members, who will register with the Platform and will be reference contact for Enel.

All the members of a Team shall comply with the eligibility requirements provided herein. The Team leader will be directly liable toward Enel for the compliance of the others Team members with this Regulation.

It will not be possible to participate simultaneously both as an individual and within a Team to the Challenge. The participation in any capacity as a single and/or in more than one Team will result in the exclusion from the Challenge of both the individual subject and the Team(s) of which it appears to be a member.

1.2. EXCLUSIONS

Enel and all the companies of the Enel Group, including their employees, directors and representatives cannot participate in this Challenge.

Furthermore, the following persons are not eligible to participate:

- All the people involved in the organization and management of the Challenge and all the people admitted to the Platform back office, as well as their spouses or partners and their relatives up to the fourth degree determined according to Italian law;
- Spouses, partners or any of their relatives up to the fourth grade (determined according to Italian law) of Enel Group companies' employees.

It is the Participant's responsibility to verify with the members of his/her kinship or spouse or partners (or with regard to his/her team members) whether any of them is connected in any way to the Challenge or the Platform.

Enel has the right to verify at any time each Participant's eligibility and compliance with this Regulation and to terminate any Participant's participation in the Challenge if, based on the Enel's investigation, the Participant results in breach with the provisions of this Regulation.

Individuals who are prohibited, at the time of participation, from exercising their profession or business, either by law or by contract or disciplinary measures, are excluded from the Challenge

(together with the Participant and/or Team in which they are involved, if any).

1.2.1. Prohibited behaviors

Participants are not allowed to post, upload, transmit, distribute or publish on the Platform and/or to submit a Solution that consists in the following materials:

- Illegal, slanderous, defamatory, offensive, fraudulent, pornographic, sexually explicit, threatening material or material violating privacy law and regulations;
- Material which may represent, encourage or provide instructions for a crime or which may violate state, national or international laws;
- Material violating third party's rights, including intellectual property rights;
- Material copied or inspired by the one proposed by another Participant;
- Material which may result in any way dangerous for minors;
- Virus, malware or other hazardous files;
- Material limiting the use or the fruition by any other Participants or the participation in the Challenge, or material which may expose Enel S.p.A and/or Enel Group entities to any liability;
- Material violating the Regulation, any other document and/or guideline published on the Platform, and/or applicable law;
- AI systems and documents non-compliant with Regulation (EU) 2024/1689 (AI Regulation) and any other applicable European Union or Italian laws regarding artificial intelligence.

Enel reserves the right to exclude from the Challenge any Participant whose proposed Solution is not in compliance with the above provisions and/or does not comply with all the minimum conditions of the Technical Specification. Moreover, Enel reserves the immediate right to exclude from the Challenge a Participant if the Participant: (i) does not comply with the Terms of Use of the Platform and/or with this Regulation, (ii) tamper with the submission process, the Challenge, or the Platform; or (iii) act in an uncooperative, unsportsmanlike, disruptive, abusive, or threatening manner.

2. EVALUATION PROCESS

2.1.1. PHASE 1

The documents constituting the Solution submitted for the PHASE 1 are listed in detail in the Technical Specification.

At the end of the PHASE 1 of the Challenge, Solutions will be evaluated on the basis of the criteria set out in the Technical Specification.

The selection of Solutions that will be admitted to the PHASE 2 of the Challenge shall be carried out by a panel composed of experts and professionals from within Enel Group (the "**Selection Panel**"), which may include *inter alia* the sole director and the top managers of Enel Green Power S.p.A.. Enel reserves the right to modify the composition of the Selection Panel at its sole discretion, ensuring that all members possess the required expertise and impartiality to conduct the relevant evaluation. The decisions of the Selection Panel shall be final and binding, and no objections or claims shall be admitted.

Based on the above criteria and on the assessment of the degree of compliance with the applicable Technical Specification, only the best proposed Solutions will be selected by the

Selection Panel to advance to the PHASE 2 of the Challenge. The number of Participants who will be admitted to the PHASE 2 will be determined by the Selection Panel depending on the number of and the general level of the proposed Solutions.

2.1.2. PHASE 2

The documents constituting the Solution presented for the PHASE 2 are listed in detail in the Technical Specification.

During the PHASE 2 of the Challenge, the Solutions will be evaluated on the basis of the criteria set out in the Technical Specification.

At the end of the PHASE 2, a final ranking will be established among the selected finalists, with projects being graded in descending order based on merit, from the highest-ranked proposal in first place to the lowest-ranked among the finalists.

2.1.3. JURY

During the PHASE 2 the proposed Solutions will be evaluated by a panel of experts appointed by Enel (the “**Jury**”). The Jury will be selected according to criteria of transparency and competence. It will be composed of members with voting rights, as follows:

- The majority of the Jury members will be employees, directors and/or representatives of Enel Group companies and may include *inter alia* the CEO and the top managers of Enel S.p.A.;
- Any Jury member not appointed in accordance with the point above shall be university professors and/or university presidents and/or professionals of recognized standing.

Each member of the Jury will be required to declare, prior to the commencement of the evaluation process, that they have no direct or indirect interest in the Challenge and are not related, affiliated, or otherwise connected to any of the Participants, whether through personal, professional, financial, or other relationships that may give rise to a conflict of interest or compromise their impartiality.

Should any conflict of interest or lack of impartiality arise or be discovered at any moment during the Challenge, Enel shall have the authority to remove and replace the affected Jury member to ensure the fairness, integrity, and transparency of the evaluation process. Moreover, Enel reserves the right, at its sole discretion, to replace one or more members of the Jury in the event of their temporary or permanent unavailability.

All decisions of the Jury shall be deemed valid only if taken in the presence of all its members and approved by an absolute majority vote. Minutes of all deliberations and decisions of the Jury shall be duly recorded in written minutes.

One member of the Jury, selected by Enel among those appointed as employees, directors, or representatives of Enel Group companies, shall be designated as the “**Chairperson**” of the Jury. The Chairperson shall be responsible for overseeing and coordinating the activities of the Jury, ensuring that the evaluation process is conducted in a fair, transparent, and orderly manner, in full compliance with the provisions of this Regulation. The Chairperson shall also have the authority to establish the place (in presence and/or by remote means), modalities and time for conducting the evaluation works, resolve any procedural matter that may arise during the evaluation process and ensure that all Jury members could express their opinions and vote before all decisions are made. Chairman may act directly and/or by means of one or more delegates.

2.1.4. General provisions

The files constituting the proposed Solution for PHASE 1 should be collected in single compressed folder (ZIP), that together with the other files (e.g. on eligibility) does not exceed the size of 35 MB for their submission through the Portal.

Participants are granted free of choice regarding the representation of their Solution, within the limits specified in the Technical Specification: the documents may be supplemented by illustrative texts, any graphic/functional diagrams, photo-insertions and anything else deemed useful for an exact understanding of the proposals submitted, in the scale deemed most suitable.

All the documents constituting the proposed Solution must be in a printable format.

The Jury will consider each proposal, getting in touch with the Participants (directly or by means of third parties appointed to this purpose) if additional information is needed, at its own discretion. Enel reserves the right to ask for additional evidence or documents to validate that all information supplied with the Solution by Participants are true and complete. Each Participant thereby agrees to provide reasonable assistance and additional information concerning its proposed Solution to Enel and/or the Jury, if requested. The decisions of the Jury shall be final and binding and no objections or claims shall be admitted.

Please be aware that Enel may terminate without prior notice the Challenge in the event that none of the proposed Solutions satisfy its expectations, without the Participants being able to claim any compensation for costs or expenses. Moreover, Enel has the absolute and sole discretion to decide whether or not to accept any proposed Solution and whether to award a prize, multiple prizes, or no prize at all, notwithstanding the determination of the Jury. Meeting the Technical Specification does not automatically mean that the proposed Solution will be accepted by Enel.

Each Participant acknowledges and agrees:

- That Enel is not responsible for, and has no liability for, not selecting any winning Solution or for selecting one or more specific winning Solutions;
- To indemnify and hold Enel harmless from any and all liabilities, losses or damages of any kind arising from or in connection with the use of any indication, information, advice, suggestions, *et similia* provided with the proposed Solutions and/or the Enel's use of the proposed Solutions;
- To indemnify and hold Enel harmless from any and all liabilities, losses or damages of any kind arising from or in connection with the Participant's participation in this Challenge.

3. AWARD

3.1.1. PRELIMINARY PRIZE

At the conclusion of the PHASE 1, each Participant selected to proceed to the PHASE 2 (the "**Admitted Participants**") shall be awarded a monetary prize (the "**Preliminary Prize**") as recognition for the general quality of their proposed Solution.

The Preliminary Prize is equal to 5.000 euro for each Admitted Participant.

For the avoidance of doubts, the Preliminary Prize shall be deemed to include all ancillary charges (including, but not limited to, payments to professional social security funds, etc.) as well as any applicable taxes. Admitted Participants shall provide all necessary documentation and information for the disbursement of the Preliminary Prize, including any invoice, tax and financial compliance certificates as may be required under applicable laws and regulations.

In the case of Teams, the Award shall be disbursed directly to each individual Team member in equal parts. The total sum of the payments made to all Team members shall not exceed the overall amount allocated to the Team.

The payment of the Preliminary Prize will be subject to the verification of the eligibility requirements and compliance with all obligations set forth in this Regulation.

The awarding of the Preliminary Prize does not in any way constitute an obligation or commitment on the part of Enel to further engage with the Admitted Participants beyond the scope of this Challenge.

3.1.2. FINAL AWARDS

At the end of the Challenge, the Jury will identify the winners, meaning the Participants that have presented the best Solutions, communicating the outcome via e-mail and/or by means of the Platform. Enel may decide to announce to the public the awarding of the Challenge, as well as the Participants who won, through any other viable digital or non-digital means.

The Participants whose Solutions are selected as winning proposals by the Jury (the **“Winners”**) shall be awarded a monetary prize as specified below (the **“Award”**):

General Awards

The Solution/s voted by the Jury to be the best overall proposals admitted in the PHASE 2, based on all the evaluation criteria and all Technical Specification, will be granted the following Awards:

- The first prize: 250.000 euro;
- The second prize: 150.000 euro;
- The third prize: 50.000 euro.

Special Awards

The Solution/s selected by the Jury to be the best proposal for the PHASE 2 for each of the following specific categories will be granted the following additional Awards:

- Design: 15.000 euro;
- Technical and Economical Feasibility: 15.000 euro;
- Innovation and sustainability: 15.000 euro.

Participants awarded a General Award shall not be eligible to receive any of the Special Awards.

The Award shall be deemed all-inclusive and lump sum, and the Participants expressly waive any right to claim any additional sums beyond the amount granted under this paragraph, on any grounds whatsoever. For the avoidance of doubts, the Award shall be deemed to include all ancillary charges (including, but not limited to, payments to professional social security funds, etc.) as well as any applicable taxes.

The Winners shall be required to issue a valid invoice and/or an equivalent tax document, provide proof of social security compliance, any other document necessary to proceed with the payment in compliance with the applicable law and demonstrate adherence to financial flow traceability requirements, as applicable. Such documentation shall be submitted exclusively through the Platform or through the means that will be requested by Enel.

In the case of Teams, the Award shall be disbursed directly to each individual Team member in equal parts, in accordance with the total amount assigned to the Team. Each Team member shall be responsible for issuing the relevant invoice or equivalent tax document. The total sum

of the payments made to all Team members shall not exceed the overall Award allocated to the Team.

Payment shall be made within 90 days from the date of receipt of the complete and correct documentation, provided that all required verifications concerning the Winner have been successfully concluded, including its compliance with the eligibility requirements, fulfillment of all obligations set forth in this Regulation, and, in particular, fulfillment of intellectual property protection obligations related to the rights to be assigned to Enel as a result of this Regulation.

Winners accepts that Enel may mention them and their Solution in relation with any communication regarding the Challenge, bearing the names of the respective author/s, without granting any specific compensation to them.

The awarding of the Award does not in any way constitute an obligation or commitment on the part of Enel to further engage with the Winners beyond the scope of this Challenge.

4. INTELLECTUAL PROPERTY RIGHTS

By submitting a proposed Solution to this challenge, each Participant accepts the following.

4.1. ADMITTED PARTICIPANTS

Each Participant accepts that the awarding of the Preliminary Prize results in the irrevocable assignment to Enel of the ownership of any and all actual and potential design rights contained in the proposed Solution. This assignment includes the right of Enel to (directly and/or with third parties) commercially exploit the design of their Solution, as well as, without limitation to, implement, reproduce, publish, exhibit, authorize third parties to use, execute, distribute, adapt, revision, modify, translate, create derivative works from, and otherwise use the design of the Solution in any manner it deems appropriate. Furthermore, Enel shall have the exclusive right to file any registration/ application for protection rights on the Solution design and/or any derivative works arising from its transformation, revision, or modification.

Without prejudice to the assignment above, the Admitted Participant also undertakes to sign a separate written agreement ("**Design Agreement**") with Enel for the final acknowledgement of Solution design ownership transfer as provided herein. Enel will pay the award to the Admitted Participant only after the final signature of the Design Agreement.

The Admitted Participant undertakes to provide Enel with the materials used for the development of the winning Solution design (including, but not limited to, blueprint, technical drawing, cad files, etc.) upon the execution of the Design Agreement.

For sake of clarity, moral rights (e.g., the right to be acknowledged as its author) on the Solution design will remain vested in the Admitted Participant. Admitted Participants expressly acknowledge and accept that the Preliminary Prize constitutes the sole and complete consideration for the transfer of the design as mentioned above and, therefore, henceforth waive any present or future claim for additional compensation, indemnification, or reimbursement in relation to such transfer, on any grounds whatsoever.

For the purpose of this Article 4.1, "design" means, as defined under Directive (EU) 2024/2823, the appearance of the whole or a part of a product resulting from the features, in particular the lines, contours, colors, shape, texture and/or materials, of the product itself and/or of its decoration, including the movement, transition or any other sort of animation of those features.

4.2. WINNERS

Each Participant accepts that the awarding as a Winner of this Challenge results in the irrevocable assignment to Enel of the ownership of the proposed Solution and of any and all

actual and potential intellectual property rights over the same. This assignment includes the right of Enel to (directly and/or with third parties) commercially exploit the Solution, as well as, without limitation to, implement, reproduce, publish, exhibit, authorize third parties to use, execute, distribute, adapt, revision, modify, translate, create derivative works from, and otherwise use the Solution in any manner it deems appropriate. Furthermore, Enel shall have the exclusive right to file any registration/ application for intellectual property rights protection on the Solution and/or any derivative works arising from its transformation, revision, or modification.

Without prejudice to the assignment above, the Winner also undertakes to sign a separate written agreement (“**IPR Agreement**”) with Enel for the final acknowledgement of transfer of ownership of the Solution and of the related intellectual property rights as provided herein.

For sake of clarity, moral rights (e.g., the right to be acknowledged as its author) on the Solution will remain vested in the Winner. Winners expressly acknowledge and accept that the Award constitutes the sole and complete consideration for the transfer of the intellectual property rights as mentioned above and, therefore, henceforth waive any present or future claim for additional compensation, indemnification, or reimbursement in relation to such transfer, on any grounds whatsoever.

Enel will pay the award to the Winner only after the final signature of the IPR Agreement.

The Winner undertakes to provide Enel with the materials used for the development of the winning Solution (including, but not limited to, blueprint, technical drawing, cad files, etc.) upon the execution of the IPR Agreement.

Enel, at its own discretion, may use the names of the authors of the winning Solution for communication purposes and in case of realization of products deriving from the winning Solution developed in the framework of the Challenge.

For the purpose of this Regulation “intellectual property rights” mean any and all recognized intellectual property rights protectable under the applicable law, such as patents, utility models, domain names, trademarks, applications for any of the foregoing, software, firmware, copyrights, databases, trade secrets, know-how and any and all other information or intangible proprietary information protectable under the applicable law.

4.3. OTHER PARTICIPANTS

Each Participant whose Solution does not receive the Award but nonetheless meets the minimum Technical Specification for participation in the Challenge, hereby acknowledges and agrees that Enel shall have an exclusive option for a period of one (1) year from the conclusion of the Challenge (meaning the date in which the winning Solutions are declared) to purchase any intellectual property rights (IPR) associated with the submitted Solution.

In the event Enel exercises such option right, the relevant Participant shall be deemed to have reached a ranking equivalent to that of the lowest-place Winner of the General Awards and shall be entitled to receive the corresponding Award. Consequently, the Participant shall be obligated to enter into the IPR Agreement under the same terms and conditions under section 4.2 above.

Accordingly, all Participants undertake to preserve, maintain, and refrain from transferring, licensing / authorizing to use or assigning to third parties any intellectual property rights related to their proposed Solution for the entire duration of the Challenge and of Enel’s option. Furthermore, Participants shall ensure that the Solution remains strictly confidential until the expiration of Enel’s option.

4.4. FREEDOM TO OPERATE AND IP PROTECTION

Upon the submission of the proposed Solution, each Participant warrants Enel to have all the rights necessary to submit the proposals and to transfer all of the rights thereof to Enel as

provided by this Regulation, and specifically that:

- Proposed Solution is an original work created solely by the Participant, and does not incorporate any third parties' content (including, but not limited to copyrighted material such as writings, text, graphics, artwork, logos, photographs, musical recordings, video clips, source codes, designs, etc.), without prejudice to the part of the proposed Solution that is generally included in the state of the art and which is freely available for use without restrictions of any kind;
- The Participant owns all the rights, including, but not limited to, all intellectual property rights on the Solution and has not assigned, licensed, or otherwise transferred any rights to third parties, nor granted any security interest, lien, or encumbrance over the Solution, and therefore no natural or legal person other than Participant has any right, title or interest in the Solution;
- The assignment by the Participant of the winner Solution and any intellectual property rights on it to Enel will not result in any infringement or violation of third parties' rights;
- The Participant is not subject to any contractual or legal obligation, including but not limited to confidentiality agreements, non-compete clauses, or other agreements, that would prevent, restrict, or otherwise interfere with the transfer and full enjoyment of the winning Solution by Enel;
- No third party has raised, or will reasonably raise, any claim or dispute of rights over the Solution and its worldwide exploitation;
- No intellectual property rights, whether owned by the Participant or by any third party, are necessary for Enel to use, implement, exploit, or commercialize its winning Solution in any manner, without restrictions.

Enel is not requested to verify the legitimacy of the Participant's use of the proposed Solution and any issues arising from third party claims relating to the proposed Solution that may arise are the sole responsibility of the Participant; nonetheless, Enel reserves the right to disclose the identity of the Participant to any third party claiming that the material posted or presented by the Participant for this Challenge constitutes a violation of their intellectual property, confidentiality and/or other rights.

Each Participant shall fully indemnify, defend, and hold harmless Enel and its affiliates, officers, directors, employees, agents, successors and assignees from and against any and all claims, demands, liabilities, damages, losses, costs, and expenses (including, without limitation, reasonable legal fees and court costs) arising out of, or related to, any breach of the representations and warranties set forth in this Regulation, including, but not limited to, any claim by a third party alleging that the use, implementation, exploitation, or commercialization of the Solution by Enel or its affiliates infringes or misappropriates any intellectual property rights.

The obligations set forth herein shall survive the termination or expiration of the Challenge and/or any contractual relationship between the Participant and Enel.

Please be aware that, by accepting this Regulation, Participant also agrees that: (i) all materials associated with proposed Solutions during the Challenge will not be returned by Enel; and (ii) Enel and Enel Group companies have the right to use any and all the names, likenesses, voices and images of all persons participating to the Challenge for future advertising, promotion and promotion activities in any manner and in any medium now known or hereafter devised throughout the world in perpetuity.

5. REPRESENTATIONS AND WARRANTIES

By proposing the Solution, the Participant represents and warrants that:

- He/she is eligible to participate in the Challenge;
- He/she accepts to abide by this Regulation;
- All his/her personal information (“**Participant Information**”) is true, accurate, current, and complete and the Participant will update its Participant Information to keep it true, accurate, current and complete;
- All the other information contained in his/her proposed Solution is true, accurate and complete;
- He/she has viewed and accepts the privacy policy of the Platform, available at <https://openinnovability.enel.com/privacy-policy>, and undertakes to comply with EU Regulation 2016/679 (“**GDPR**”) and any other applicable privacy legislation;
- The proposal of the Solution within the Challenge under this Regulation complies with any regulation and/or policy of the institution, company or firm with which the employment or collaboration relationship of the Participant is in place. If Enel has reason to believe that the Participant may violate any of those regulation and/or policies, Enel reserves the right to exclude the relevant Participant from the Challenge or to withheld any Award at any time;
- The Participant has not breached any laws in his/her country of residence by participating in the Challenge;
- The Participant is not in a position of conflict of interest with this Challenge;
- The proposed Solution is generated and developed exclusively for the Challenge and does not: (i) violate the rights of any third party; (ii) prominently feature any trademarks or logos; (iii) contain content that is defamatory or in violation of any law, irrelevant to the Challenge, or otherwise inappropriate, as determined by Enel in its sole discretion.

6. CONFIDENTIALITY

By submitting a proposed Solution, you undertake to mark any confidential information, if any, as “strictly confidential”. Enel undertakes, for the term of the Challenge and for one (1) year following its conclusion, to treat as confidential any information marked as “strictly confidential” by the Participant and to not disclose such confidential information to any third party not directly involved by Enel in the selection and evaluation process of the proposed Solutions. Therefore, you acknowledge and agree that Enel may decide to share, under bond of confidentiality and in respect of the applicable laws, the proposed Solution to third-parties and to any Enel Group’s company that are involved by Enel in the selection process and/or in the evaluation of the proposed Solutions within the Challenge.

At the time you submit any proposed Solution, in whole or in part, on Platform and/or through the other means indicated by Enel, and whether or not your proposed Solution is selected, you are aware that the proposed Solution and associated materials (if any) shall be used for the evaluation of the proposed Solutions within the Challenge and will not be returned.

Enel and Enel Group companies are in no way obligated to use or continue to use your proposed Solution (and have no obligation to you or any other person or entity after your proposed Solution is received). However, each Participant acknowledges and agrees that by participating in the Challenge it expressly authorizes Enel to use the documents provided with the proposed Solution which are not marked as “strictly confidential” for dissemination and/or exhibition purposes, without implying any economic or other claim on the part of the same Participants.

Notwithstanding the foregoing, upon submission of the Solution, each Participant hereby undertakes to maintain the confidentiality of all information contained therein, as well as of any information provided by Enel which is specifically indicated to be “strictly confidential”, for the entire duration of the Challenge and for one (1) year following its conclusion, with the sole

exception of the Winners' Solutions, for which confidentiality obligations shall remain in effect until such information has become generally known for causes other than its disclosure by the relevant Winner. This confidentiality obligation is expressly intended to safeguard the potential protection (e.g., patentability) of any innovative aspects embodied in the Solution, which Enel may acquire pursuant to article 4 of this Regulation. Participants acknowledge that any unauthorized disclosure to third parties may compromise the novelty essential for patent protection. Accordingly, Participants shall not share, disclose, or otherwise make available any part of their Solution submitted to any third party without Enel's specific prior written consent. However, confidential information shall not be construed as including any information that is or comes into the public domain for a reason different from any breach of the present Regulation.

7. DATA PROTECTION

Participation to the Challenge is conditioned on providing the data required on the online registration form on Platform.

Participants should not register with multiple e-mail and/or street addresses. In the event of a dispute as to any proposed Solution, the authorized account holder of the email address used to enter will be deemed to be the person who submitted the proposed Solution. The authorized "account holder" is the natural person assigned an email address by an Internet access provider, online service provider or other organization responsible for assigning email addresses for the domain associated with the submitted address.

Personal data will be processed in accordance with Platform's Privacy Policy which can be located at <https://openinnovability.enel.com/privacy-policy>.

When the Participant accesses the Platform and submits a Solution, ENEL S.p.A. and other ENEL Group companies that consider the Solution interesting or to be better investigated, become the independent Data Controller of the processing of all the information provided by the Participant. Enel will transfer only Personal Data necessary to perform the contractual obligations or necessary for pre-contractual measures to allow the participation to the Challenge.

8. DECLARATION OF HONOR

By submitting the proposal, the Participant declares that he/she is not in one of the following situations:

- He/she is bankrupt or being wound up, is having its affairs administered by the courts, has entered into an arrangement with creditors, has suspended its business activities, is the subject of proceedings concerning those matters, or is in any analogous situation arising from a similar procedure provided for in national legislation or regulations;
- He/she or persons having powers of representation, decision making or control over him/her have been convicted of an offence concerning their professional conduct by a judgment which has the force of *res judicata*;
- He/she has been found guilty of serious professional misconduct proven by any competent court or public authority;
- He/she is not in compliance with his/her obligations relating to the payment of social security contributions or the payment of taxes in accordance with the legal provisions of the country in which it is resident or with those of the country of Enel or those of the country where the Challenge is carried out;
- He/she or persons having powers of representation, decision making or control over him/her have been the subject of a judgment which has the force of *res judicata* for fraud, corruption, involvement in a criminal organization or any other illegal activity;

- He/she is subject to a conflict of interest;
- He/she has made false declarations in supplying the information required, as a condition of participation in the Challenge or does not supply this information;
- He/she is in one of the situations of exclusion, referred to in this Regulation.

The Participant undertakes to inform Enel immediately, if between the date of submission and the end of the evaluation process, any of the above issues arise. In the above cases, Enel may consider excluding the relevant Participant from the Challenge.

9. ETHIC CLAUSE

Enel in the pursuit of its business activities and in their relationship management, refers to the principles contained in the Code of Ethics, in the «Zero Tolerance against corruption plan» (TZC Plan), in the Organizational model in accordance with the decree 231/2001 and in the Human Rights Policy available at the internet address: <https://www.enel.com/investors/sustainability/daily-commitment/sound-governance-ethical-conduct/principles-underpinning-our-work>.

Participants hereby acknowledge the Code of Ethics of the Enel Group as binding and confirm to adhere to it. Participants also acknowledge that Enel S.p.A. has approved the Enel Global Compliance Program, which was drafted taking into account the main international conventions against corruption (i.e. Bribery Act; Foreign Corrupt Practice Act etc.) and which is adopted by all non-Italian subsidiaries of the Enel Group.

Enel reserves the right to reject any proposal that does not comply with the abovementioned requirements. If the Challenge is won by a Participant not meeting the cited requirements, such Participant will lose the right to the Award.

10. CHANGES TO THE REGULATION.

By submitting the proposal, the Participants acknowledge that Enel may vary this Regulation at any time at its sole discretion. This includes changes to dates for deadlines and events, locations, or specifications of the Challenge.

Any changes to this Regulation will be communicated by means of the Platform and/or by the other means that Enel will consider appropriate on a case by case basis and will be valid from the time of its publication.

Participants should regularly visit the Platform to check if any update of the Regulation has been posted.

Enel reserves the unilateral right to withdraw from the Challenge at any time, as well as to suspend, discontinue, terminate early the Challenge, at its sole discretion.

11. COSTS.

Any cost relevant to the participation to the Challenge shall be exclusively borne by the Participants.

Participants shall have no right to claim any reimbursement, compensation, or indemnification from Enel or any company within the Enel Group, on any grounds whatsoever, including but not limited to any costs, expenses, or losses incurred in connection with their participation in the Challenge, even if due to its early termination, modifications, or any other similar circumstances.

12. LIMITATION OF LIABILITY.

In addition to any other limitation of liability contained in this Regulation, Enel and Enel Group companies are not liable for any possible deficiencies of the Platform, the other means used for the Challenge and/or for the decision of awarding or not awarding any and/or all of the Awards. Furthermore, Enel and its Affiliates are not responsible for problems regarding computers, networks or any other reasons that may lead to lost, damaged and/or late entries.

Please note that this Challenge does not constitute a public offer under Article 1336 of the Italian Civil Code.

13. GOVERNING LAW AND DISPUTE RESOLUTION.

This Regulation and any matters arising from or related to it shall be governed by and interpreted in accordance with the laws of Italy. Any dispute, controversy or claim arising out of or relating to this Regulation (including any question regarding its existence, validity or termination) shall be exclusively settled by the competent Civil Courts of Rome.

According to Article 1341 and 1342 of the Italian Civil Code, the Participant expressly declare to have fully understood and to accept the following clauses of this Regulation:

Article 1.2 (EXCLUSIONS), Article 2.1.1 (PHASE 1), Article 2.1.4 (GENERAL PROVISIONS), Article 3 (AWARD), Article 4 (INTELLECTUAL PROPERTY RIGHTS), Article 5 (REPRESENTATIONS AND WARRANTIES), Article 6 (CONFIDENTIALITY), Article 8 (DECLARATION OF HONOR), Article 9 (ETHIC CLAUSE), Article 10 (CHANGES TO THE REGULATION), Article 11 (COSTS), Article 12 (LIMITATION OF LIABILITY), Article 13 (GOVERNING LAW AND DESPUTE RESOLUTION).

ESPECIFICAÇÕES TÉCNICAS

Índice

1. OBJETIVO
2. PADRÕES E REQUISITOS
3. FASE 1 - Propostas de ideias
4. FASE 2 - Projeto detalhado
5. ENTREGÁVEIS
 - FASE 1
 - FASE 2
6. AVALIAÇÃO - CRITÉRIOS DE PREMIAÇÃO
7. ANEXO I

1. OBJETIVO

O objetivo deste documento é delinear os critérios necessários para projetar novos tipos de turbinas eólicas que repensem a estética das usinas de energia eólica por meio de soluções inovadoras: combinando funcionalidade, design, inovação e sustentabilidade para melhorar a harmonia entre a infraestrutura e a paisagem, reduzindo o impacto ambiental.

Em particular, as soluções propostas devem atender aos seguintes requisitos como princípios gerais:

- **Aumentar a integração ambiental e paisagística:** baixo impacto visual e/ou acústico;
- **Viabilidade técnica e funcional:** a solução deve garantir o correto funcionamento que garanta a geração de energia.
- **Flexibilidade de uso:** adaptável a qualquer fornecedor de turbina;
- **Sustentabilidade econômica:** simplicidade de construção que não comprometa o investimento, assim como a operação ou manutenção.

2. NORMAS E REQUISITOS

As soluções propostas para novos projetos de turbinas eólicas devem ser desenvolvidas de acordo com as regulamentações atuais e as normas técnicas aplicáveis.

A solução proposta deve estar em conformidade com as seguintes restrições:

a) Normas de projeto: a menos que seja indicado de outra forma nesta especificação, as propostas sujeitas a submissão devem ser projetadas de acordo com os padrões técnicos aplicáveis, incluindo, mas não limitado, à norma internacional sobre turbinas eólicas IEC 61400 em suas partes aplicáveis à solução proposta e conforme fornecido pela Organização de Aviação Civil Internacional - (International Civil Aviation Organization - ICAO);

b) Tipo de turbina e viabilidade técnica: }Deve-se entender que a turbina está constituída na sua totalidade pelos seguintes componentes: lâminas, nacele, cubo e torre na configuração de eixo horizontal (3 lâminas) de nova geração com as seguintes características:

- Potência nominal = 5 - 6MW
- Diâmetro do rotor = 150 - 175 m
- Altura do cubo = 90 - 120 m

c) A solução proposta deve garantir o desempenho padrão de mercado da geração de energia, portanto, deve respeitar as características e funções essenciais típicas de uma turbina eólica, de modo que nenhuma modificação deve ser feita nas partes mecânicas/elétricas dentro de uma turbina padrão e na geometria das pás

d) Aspectos ambientais: a solução proposta deve:

- Considerar as diretrizes fornecidas pela Corporação Financeira Internacional - Diretrizes de Ambientais, de Saúde e Segurança (EHS - Environmental, Health, and Safety), que definem os aspectos ambientais mais impactados;
- Evitar superfícies nas naceles que possam ser usadas como poleiros por pássaros e morcegos;
- Melhorar a percepção da turbina eólica por meio de uma melhor integração à paisagem, incluindo o uso de revestimentos, mas sempre respeitando a melhor solução técnica possível.

3. FASE 1 - Propostas de ideias

Uma proposta para novos tipos de turbinas eólicas deverá ser desenvolvida e enviada para aprovação da ENEL, com o objetivo de identificar possíveis soluções a serem implementadas a nível de projeto na fase subsequente.

Nesse sentido, não há limitações em termos de geometrias, materiais e soluções de construção além do que é indicado no ponto nº 2: "NORMAS E REQUISITOS"; no entanto, é necessário verificar a viabilidade da estrutura proposta com processos industriais e materiais facilmente disponíveis no mercado.

4. FASE 2 - Projeto detalhado

Nessa fase, a ideia de solução proposta durante a Fase 1 e admitida na Fase 2 deve ser desenvolvida mantendo-se as características propostas tanto quanto possível, a menos que alguma consideração técnica comprometa a viabilidade. A documentação a ser fornecida durante a Fase 2 deve conter todos os elementos necessários para a compreensão dos aspectos mecânicos, estruturais e funcionais do novo tipo de solução proposta.

Durante a Fase 2, é necessário cumprir as seguintes restrições na definição da solução proposta:

a) Construtibilidade: a solução proposta deve ser concebida considerando a necessidade de garantir a construtibilidade da obra em todas as suas fases: construção e operação em coerência com os meios de montagem utilizados no setor de usinas industriais;

b) Sustentabilidade: a solução proposta deve prever o uso de materiais sustentáveis e duráveis, pelo menos iguais aos atuais, com processos para reduzir as emissões de CO₂. Nesse sentido, uma Avaliação do Ciclo de Vida (LCA - Life Cycle Assessment) simplificada deve ser produzida de acordo com a UNI EN ISO 14040 - 14044 com uma unidade funcional definida em 1 kWh para atividades que ocorrem antes da construção, tal qual a fabricação de componentes e materiais. Tomando como referência uma turbina de 5 a 6 MW operada por 20 anos, um local com 3.000 horas equivalentes com um valor de referência de 5 a 7g de CO₂/kWh.

c) Cargas da fundação: Para conter os impactos nos custos, a solução proposta deve limitar o aumento das cargas da fundação. Consulte o Anexo I para obter os dados de carga da fundação.

5. ENTREGAS

Os documentos a serem enviados nas duas fases são considerados obrigatórios para permitir a avaliação da solução proposta.

FASE 1

Documentos técnicos:

- Relatório técnico descritivo da solução proposta com informações de dimensão e geometria, uso de materiais adotados e um dimensionamento técnico/estrutural preliminar.

- Renderização da solução proposta com inserções de fotos relacionadas em 2 ou 3 contextos (por exemplo, Puglia, Sicília e norte da Espanha).

Documentos econômicos e cronograma:

- Estimativa preliminar de custos: projeto, materiais, processamento, tempos de montagem, custos operacionais;
- Roteiro preliminar para o projeto (cronograma esperado e principais marcos de desenvolvimento do projeto).

Documentos administrativos:

- Declaração de que a solução proposta está em conformidade com as restrições da seção 2, acompanhada de uma explicação detalhada e fundamentada que demonstre como cada requisito aplicável foi atendido.

FASE 2

Documentos técnicos explicativos:

- Relatório descritivo da solução e dos materiais adotados com indicação das porcentagens de materiais recicláveis a serem usados;
- Desenhos arquitetônicos e estruturais detalhados da solução proposta com renderização completa, vistas, seções, perfis arquitetônicos e estruturais, detalhes e conexões principais entre os componentes e o conceito de fundação, incluindo a estimativa de quaisquer fases de transição para operações de transporte, montagem e manutenção;
- Análise de construtibilidade (dimensões e pesos), logística de transporte, construção e manutenção, incluindo todos os cronogramas previstos necessários nas várias fases de transição e final;
- Modelo 3D da turbina eólica proposta + modelo em escala.
- LCA (Life Cycle Assessment) simplificada para a parte previa a construção com indicação dos valores de referência usados para cada material.
- Memória de cálculo estrutural da solução proposta, incluindo cargas de fundação, avaliadas para os principais casos de carga da norma IEC 61400:6. A solução descrita no Anexo I deve ser considerada para desenvolvimento futuro. Esse relatório deve destacar, por meio de comparação numérica, quaisquer aumentos nas cargas da fundação em comparação com a turbina de referência, em termos de cisalhamento, ações axiais, momentos não fatorados avaliados para a condição de operação "carga pf = 0,01 SLS 10-2 " definida pela IEC 61400:6 no ponto 3.35.

Documentos econômicos e cronograma:

- Estimativa de custo detalhada com especificações técnicas de todo o trabalho necessário para as fases de produção, montagem e operação.
- Cronograma para as fases de projeto, produção, conclusão e operação. Se necessário, dependendo da solução proposta, deve-se indicar o cronograma esperado para o processo de certificação..

6. AVALIAÇÃO

As soluções propostas serão avaliadas com base em sua conformidade com os requisitos estabelecidos na seção 2 (Normas e Requisitos) acima, nas seguintes áreas principais de interesse:

- **Design:** foco no design, novidade, impacto visual, estética, impacto ambiental e integração da paisagem;

- **Viabilidade técnica e econômica** e o cronograma do projeto detalhado e da implementação;
- **Inovação e sustentabilidade:** grau de inovação, aspectos de sustentabilidade e baixo impacto de carbono no ciclo de vida da solução proposta.

7. ANEXO I

Para soluções propostas que considerem modificações estruturais, deve-se considerar a seguinte turbina de referência e condições do aerogerador.

- Potência nominal: 5,5MW
- Diâmetro do rotor = 161 m
- Altura do cubo = 98 m

Uma análise da integridade da própria turbina, bem como dos componentes individuais e de sua fundação, precisa ser realizada e fornecida para ser avaliada para os fins do desafio.

- Condições do vento

Rated rotor speed:	10 rpm
Cut in wind speed:	3 m/s
Cut out wind speed:	25m/s
Design lifetime:	25 y
Wind Class:	S
Reference wind speed V_{ref}:	43 m/s
Annual average wind speed at hub height V_{ave}:	7.5 m/s
Turbulence Intensity:	10.5%
Weibul K:	2,5
Shear exponent:	0,25
Air density:	1.225 kg/m ³
Altitude:	< 1000 m
Operative temperature range:	-20°C / + 40%
Frequency:	50Hz

Características da turbina. Os valores devem ser usados apenas como referência:

- Dimensões e peso gerais da turbina eólica (como envolvente máxima)
 - o Pá:

Mass of each blade:	25.95 tons
Center of gravity:	21 m
Length:	78.6 m

- o Nacele e cubo:

Hub:	54 tons
Gearbox:	44 tons
Low speed shaft:	30 tons
Nacelle:	67 tons

Nacelle including drive train:	141 tons
Nacelle including drive train and hub:	195 tons
Nacelle LxWxH:	13 x 4.5 x 4 m
Tilt:	5 DEG
Conning:	4 DEG
Pre-bending:	3.8 m
Hub center offset: (blade forward position)	4.4 m
Blade tip offset: (blade forward position)	21.0 m
Hub height:	98 m

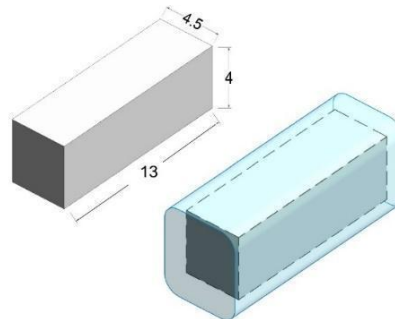

o Torre:

Tower type:	Tubular steel tower
Tower designation:	TST_98m
Material:	Steel
Length:	95.35 m
Ø Top:	3.32 m
Ø Bottom:	4.30 m
Weight:	285 ton

- Cargas de fundação:

A tabela a seguir mostra as cargas S2 [3.34 IEC 61400:6] na base da torre: valores obtidos para cada componente de carga com uma probabilidade de excedência de $pf=10^{-4}$ de acordo com a IEC 61400-6 [2].

Partial safety factor	1.0
Mxy[kNm]	87000

Mz[kNm]	-4700
Fxy[kN]	950
Fz[kN]	-5800

A tabela a seguir mostra as cargas S3 [3.35 IEC 61400:6] na base da torre: valores obtidos para cada componente de carga com uma probabilidade de excedência de $pf=0,01$ de acordo com a IEC 61400-6 [2].

Partial safety factor	1.0
Mxy[kNm]	80000
Mz[kNm]	-3000
Fxy[kN]	900
Fz[kN]	-5700

- Estratégia de controle

A estratégia de controle (algoritmo de controle e tempo de resposta dos atuadores) não é compartilhada e tem um impacto significativo nas cargas da fundação. A estratégia de controle considerada por cada participante em seu modelo pode levar a resultados de carga diferentes. É responsabilidade de cada participante garantir que a estratégia de controle assumida se alinhe aos objetivos do projeto e às suposições operacionais. Os dados e as diretrizes fornecidos são apenas para referência, e variações nas estratégias de controle podem derivar em resultados de carga diferentes.